

Valve bank (directional seated valve) type BVH

Product documentation

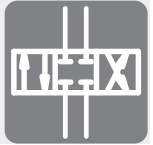

Operating pressure p_{\max} : 400 bar
Flow rate Q_{\max} : 20 lpm

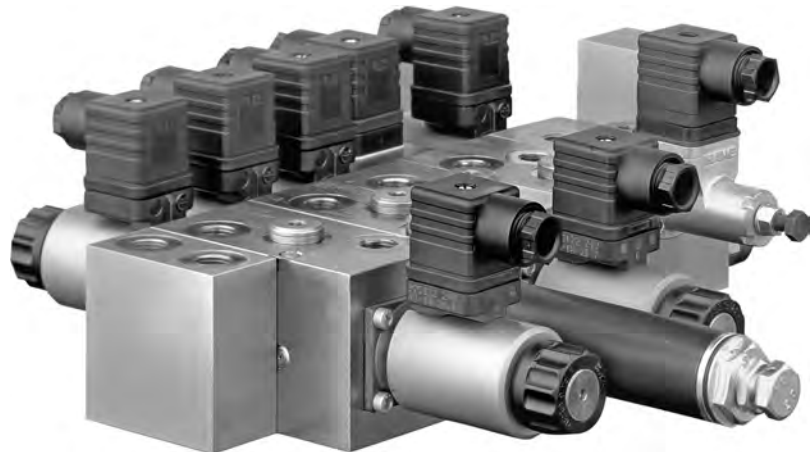

© by HAWE Hydraulik SE.

The forwarding and reproduction of this document, as well as the use and communication of its contents, are forbidden unless expressly permitted.

Any breach or infringement will result in liability for damages.

All rights reserved concerning patent or utility model application.

Contents

1	Overview of valve bank type BVH.....	4
2	Available versions, main data.....	5
2.1	Connection blocks.....	6
2.2	Valve sections and intermediate plates.....	7
2.2.1	Valve sections.....	7
2.2.2	Intermediate plates.....	10
2.3	End plates.....	14
2.4	Solenoid voltages.....	14
3	Parameters.....	15
3.1	General.....	15
3.2	Electrical data.....	17
4	Dimensions.....	19
4.1	Connection blocks.....	19
4.2	Valve sections.....	20
4.3	End plates.....	34
5	Assembly, operation and maintenance recommendations.....	36
5.1	Intended application.....	36
5.2	Assembly information.....	37
5.3	Operating instructions.....	38
5.4	Maintenance information.....	38
6	Other information.....	39
6.1	Implementation examples.....	39
6.2	Planning information.....	40
6.3	Individual components.....	40

1 Overview of valve bank type BVH

A valve bank combines different valves for operating independent consumers. The valve bank type BVH comprises several directional seated valves that are connected in parallel. As cone valves the directional seated valves have zero leakage in the closed state. The valve sections are connected using banjo bolts. 2/2, 3/2, 4/2 and 4/3-way directional seated valves are available. Depending on the functional requirement, pressure reducing valves, pressure switches, check valves, restrictors or restrictor check valves are integrated into the valve section. The valve bank can be flange-mounted directly on compact hydraulic power packs or integrated into a pipe system via a piping block.

Features and benefits:

- Flexible expandability
- Compact and lighter design (elimination of the base plates)

Intended applications:

- Auxiliary and clamping functions on machine tools and fixtures
- Auxiliary and clamping functions on forming machine tools
- Brake and rotor adjustment modules on wind turbines

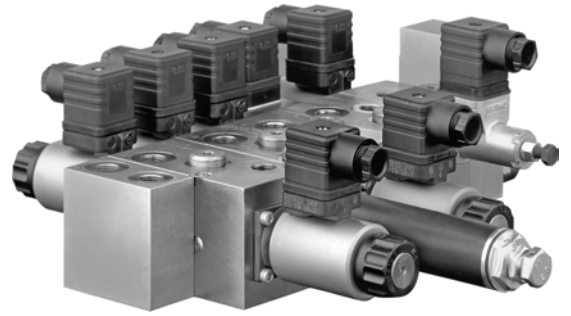

Valve bank type BVH

2 Available versions, main data

Order coding examples:

KA 2..	A1/250	- BVH 11	H	/GM	/R	/2		
		- BVH 11	M	/GM	/R B2,5	/3		
		- BVH 11	W	/GM	/O	/55		
		- BVH 11	M/CZ/35	/GM	/R	/2	- 8	- G24

Solenoid voltage Table 7 Solenoid voltage

End plate Table 6 End plate

Pressure switch Table 5 Pressure switch

Additional element Table 4 Additional element at A, B, P and R



Actuation Table 3 Actuation

Circuit symbols Table 2 Valve sections, intermediate plates

Connection block Table 1 Connection block

2.1 Connection blocks

Table 1 Connection block

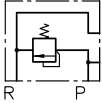
Connection block	Description	Ports (BSPP)	Circuit symbol
None	Direct mounting on connection blocks type A, D 6905 A/1 To be combined with compact hydraulic power packs Type HK D 7600-2, D 7600-3, D 7600-4 HKL D 7600-3L KA D 8010, D 8010-4 HC D 7900 MP D 7200 MPN D 7207	--	
BVH 11 A5	Version for pipe connection	G 1/4 DIN EN ISO 228-1	
BVH 12 A5		G 3/8 DIN EN ISO 228-1	
BVH 11 A5 JIS	Version for pipe connection Addition of check valve at P	G 1/4 JIS B 2351-1	
BVH 12 A5 JIS		G 3/8 JIS B 2351-1	
	No designation	--	
	/R	With check valve at P	
BVH 11 A1 JIS/...	Version for pipe connection with pressure-limiting valve	G 1/4 JIS B 2351-1	



Note

The maximum pressure is dependent on the circuit symbol (Table 2) and the actuation (Table 3).

Table 3 Actuation

Coding	Description	Pressure (bar)
GM	Solenoid actuation	250
M		400

Table 4 Additional elements at A, B, P and R

Coding for fitted parts	Description	Circuit symbol
O	None	
R	Check valve at P	R
B ...	Orifice at P	B...
RB ...		RB...
Orifices \emptyset	Orifices \emptyset 0.4; 0.5; 0.6; 0.8; 0.9; 1.0; 1.2; 1.5; 1.8; 2.0; 2.4; 2.5; 3.0; 3.5	
H	Filter element type HFC 1/4 at A or A and B	
S	Return pressure stop at T	S
TB ...	Orifice at T	TB...
Orifices \emptyset		Orifices \emptyset 0.4; 0.5; 0.6; 0.8; 1.0; 1.5; 2.0
ABR..E(F)	Restrictor check valve BC1 at A and/or B	ABR..E ABR..F BBR..E BBR..F
BBR..E(F)	Orifices \emptyset 0.2; 0.4; 0.5; 0.6; 0.8; 1.0; 1.2	
ABRX..E(F)	Restrictor check valve BC1 X at A and/or B	
BBRX..E(F)		

Table 5 Pressure switches

Pressure switches at A for circuit symbol H and M, or at A and B for circuit symbol W

Coding	Pressure switches	Adjustment range (bar)	
2	Without DG	--	Pressure switches type DG: D 5440 (mechanical pressure switch)
3	DG 33	200 ... 700	
4	DG 34	100 ... 400	
5	DG 35	20 ... 250	
6	DG 36	4 ... 12	
7	DG 365	12 ... 170	
8	DG 364	4 ... 50	
5 E1	DG 5 E-100		
5 E2	DG 5 E-250		
5 E4	DG 5 E-400		
5 E6	DG 5 E-600		
6 E1	DG 61	0 ... 100	Electronic pressure switches type DG 6: D 5440 F (two switch points)
6 ER1	DG 61 R	0 ... 100	
6 E2	DG 62	0 ... 250	
6 ER2	DG 62 R	0 ... 250	
6 E4	DG 64	0 ... 400	
6 ER4	DG 64 R	0 ... 400	

2.2.2 Intermediate plates

Intermediate plate with pressure reducing valve in the P gallery (see also Table 2a, 2b)

Order coding example:

BVH 11	CZD 2	/180	/5
		Additional elements	Table 2b Additional elements
		Pressure setting	Pressure setting (bar)
	Pressure reducing valve		Table 2a Pressure reducing valve

Circuit symbols	CZD.../5...	LZD.../5...
Max. pressure (bar)	400	400
BVH 11	●	●
BVH 11 JIS	--	--
		

Table 2b Additional elements

Coding	Description
/5	Series
/5R	Check valve at P
/5X	Port S sealed
/5RX	Check valve at P and port S sealed

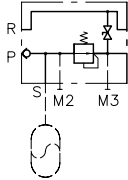
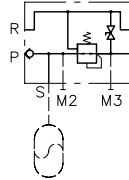

Note

The check valve can only be mounted or dismantled if the pressure reducing valve is dismantled.

Intermediate plate with pressure switches at P (see also Table 2c)

Order coding example:

BVH 11 Z1 /DG34

Pressure switches Table 2c Pressure switches

Circuit symbol	Z1/...
Max. pressure (bar)	400
BVH 11	●
BVH 11 JIS	--
	

Table 2c Pressure switches

Pressure switches	Pressure range (bar)	
DG 33	200 ... 700	Pressure switches type DG: D 5440 (mechanical pressure switch)
DG 34	100 ... 400	
DG 35	20 ... 250	
DG 36	4 ... 12	
DG 364	4 ... 50	
DG 365	12 ... 170	
DG 61	0 ... 100	Electronic pressure switches type DG 6: D 5440 F (two switch points)
DG 61 R	0 ... 100	
DG 62	0 ... 250	
DG 62 R	0 ... 250	
DG 64	0 ... 400	
DG 64 R	0 ... 400	

Intermediate plate with pressure filter (see also Table 2d, 2e, 2f)

Order coding example:

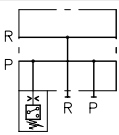
BVH 11 ZD	10	/SX	/VE
		Visual clogging display	Table 2f Visual clogging display
	preload	Table 2e Preload for bypass	
Filter unit	Table 2d Filter unit		

Circuit symbol	ZD/./SX/..	ZD/./S8/..
Max. pressure (bar)	400	400
BVH 11	●	●
BVH 11 JIS	--	--
		

Table 2d Filter unit

Coding	Description
10	10 μm , $Q_{\text{max}} = 8 \text{ lpm}$
25	25 μm , $Q_{\text{max}} = 10 \text{ lpm}$
40	40 μm , $Q_{\text{max}} = 12 \text{ lpm}$

Table 2e Preload for bypass

Coding	Description
SX	Bypass P blocked
S8	Bypass at P preloaded with 8 bar

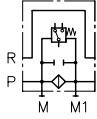
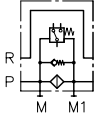
Table 2f Visual clogging indicator

Coding	Description
No designation	Without visual clogging indicator
VA	With visual clogging indicator (automatic reset), $P_{\text{max}} = 400 \text{ bar}$ Response differential pressure: 5 bar
VV	With visual clogging indicator (manual reset), $P_{\text{max}} = 400 \text{ bar}$ Response differential pressure: 5 bar
VE	With electrical visual clogging indicator, $P_{\text{max}} = 400 \text{ bar}$ Response differential pressure: 5 bar

Sub-plate for mounting NG6 valves

Order coding example:

BVH 11 - NBVP 16 G/GM/O

NG6 valve specification Type NBVP [D 7765 N](#)
 Type NSWP [D 7451 N](#)
 Type NG, NWG [D 7300 N](#)
 Type NPMVP [D 7485 N](#)

Circuit symbol	BVH 11 - ... /O
BVH 11	●
BVH 11 JIS	--

2.3 End plates

Table 6 End plate

Basic type	Description	Ports	Circuit symbol
- 1 - 1 JIS	Tapped plug at P, R Connection option at P and R	DIN EN ISO 228-1 JIS B 2351-1	
- 2	Tapped plug at P, R Connection option at R	DIN EN ISO 228-1	
- 81 - 82 - 82 JIS	With accumulator port and drain valve	DIN EN ISO 228-1 JIS B 2351-1	<div style="display: flex; justify-content: space-around;"> <div style="text-align: center;"> <p>- 81</p> </div> <div style="text-align: center;"> <p>- 82</p> </div> <div style="text-align: center;"> <p>- 82 JIS</p> </div> </div>
- 81/B ... - 82/B ...	With accumulator port, drain valve and orifice at M1 Orifices \varnothing 0.4; 0.5; 0.6; 0.8; 0.9; 1.0; 1.2; 1.5; 1.8; 2.0; 2.4; 2.5; 3.0; 3.5	DIN EN ISO 228-1	<div style="display: flex; justify-content: space-around;"> <div style="text-align: center;"> <p>- 81/B ...</p> </div> <div style="text-align: center;"> <p>- 82/B ...</p> </div> </div>

2.4 Solenoid voltages

Table 7 Solenoid voltages

Coding	Electrical connection	Pressure p_{max} (bar)	Nominal voltage	Protection class (IEC 529)
X 12 X 24 X 98 X 205 WG 110 WG 230	DIN EN 175 301-803 A (Coding G... with line connector, coding L... with LEDs in line connector) Coding WG with alternating rectifier in line connector	400	12 V DC 24 V DC 98 V DC 205 V DC 110 V AC 50/60 Hz 230 V AC 50/60 Hz	IP 65
XM 12 XM 24 XM 98 XM 205 WGM 110 WGM 230		250	12 V DC 24 V DC 98 V DC 205 V DC 110 V AC 50/60 Hz 230 V AC 50/60 Hz	IP 65
M 24/8W	M12x1	250	24 V DC	IP 67

Connection diagram

G ..., X ..., L ..., (WG)

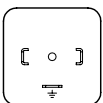

M ..

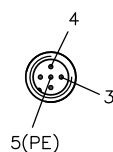

3 Parameters

3.1 General

General data

Description	According to order coding
Design	According to order coding
Model	Valve bank
Material	Steel; valve housing galvanized zinc plated; hardened and ground functional inner parts
Installation position	As desired
Hydraulic fluid	Hydraulic oil: according to Part 1 to 3; ISO VG 10 to 68 according to DIN ISO 3448 Viscosity limits: min. approx. 4, max. approx. 1500 mm ² /s opt. operation approx. 10... 500 mm ² /s. Also suitable for biologically degradable hydraulic fluids type HEPG (polyalkylene glycol) and HEES (synthetic ester) at operating temperatures up to approx. +70°C.
Cleanliness level	ISO 4406 <u>21/18/15...19/17/13</u>
Temperatures	Ambient: approx. -40 ... +80°C, Fluid: -25 ... +80°C, Note the viscosity range! Permissible temperature during start: -40°C (observe start-viscosity!), as long as the service temperature is at least 20K higher for the following operation. Biologically degradable pressure fluids: Observe manufacturer's specifications. By consideration of the compatibility with seal material not over +70°C.

Pressure and flow rate

Pressure	P 400 bar A, B According to circuit symbol and actuation R 50 bar
Flow rate	20 lpm

Weight

Type

BVH 11 M(H)	= 0.8 kg
BVH 11 W	= 1.0 kg
BVH 11 M(H)/CZ	= 1.5 kg
BVH 11 W/CZ	= 1.7 kg
BVH 11 D(G)	= 1.2 kg
BVH 11 CZD	= 0.8 kg
BVH 11 LZD	= 0.8 kg
BVH 11 Z1	= 0.5 kg

Per pressure switch

DG 3.	= 0.4 kg
DG 5.	= approx. 0.25 kg
DG 6.	= approx. 80 g

3.2 Electrical data

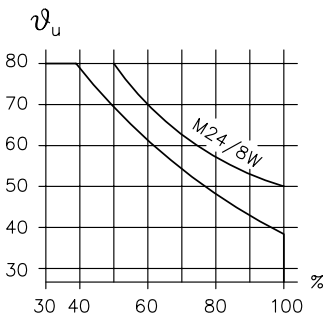
	X 12	XM 12	X 24	XM 24	M24/8W	WG 110	WGM 110	WG 230	WGM 230
Nominal power U_N	12 V DC	12 V DC	24 V DC	24 V DC	24 V DC	110 V AC	110 V AC	230 V AC	230 V AC
Nominal power P_N	29.4 W	26.2 W	27.6 W	26.5 W	8 W	28.6 W	24.8 W	30.2 W	28 W
Switching times (reference value)	On or off: approx. 50 to 60 ms, for M 24/8W and WG... 2-3 times longer								
Switching operations/h	Approx. 2000, evenly distributed								
Contact temperature	Approx. 120°C, at 20°C ambient temperature								
Cut-off energy	$W_A \leq 0.4 \text{ Ws}$								
Insulation material class	F Contact temperature at 20° ambient temperature approx. 85 to 95°C (cladding). In adhering to the reference values for % duty cycle in operation, the permissible winding limit temperature of approx. 150°C according to insulation material class F is approximately reached as a steady-state temperature. The thermal load of the coil can be reduced by means of an economy circuit, for example (see Chapter 5.4, "Maintenance information").								
Relative duty cycle (ED) 100% ED (specification on the solenoid)	Reference value and restriction in operation  <p style="text-align: center;">ϑ_u</p> <p style="text-align: center;">T ambient temperature (°C); % ED duty cycle</p>								

Circuit diagrams

DC voltage

X .., G ..
XM .., GM ..

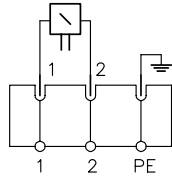

L ..
LM ..

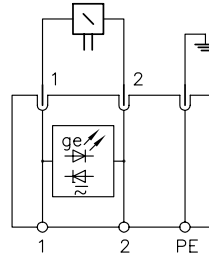

M..

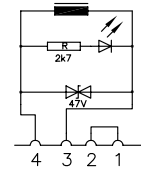

AC voltage

WG ..
WGM ..

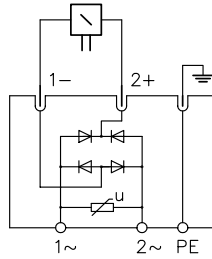

Visual clogging display
Coding VE

Technical data:

Switch

Change-over contact

Port

DIN EN 175 301-803 A



DC/AC switching capacity

30 VA

Max. DC/AC current

5 A / 0.25 A

Max. voltage

230 V DC/AC

4 Dimensions

All dimensions in mm, subject to change.

4.1 Connection blocks

BVH 11 A5
BVH 11 A5 JIS
BVH 12 A5
BVH 12 A5 JIS

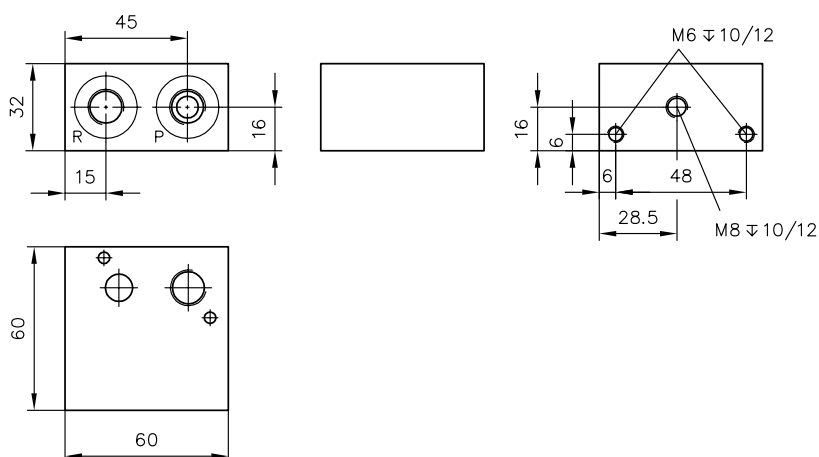

BVH 11 A1 JIS

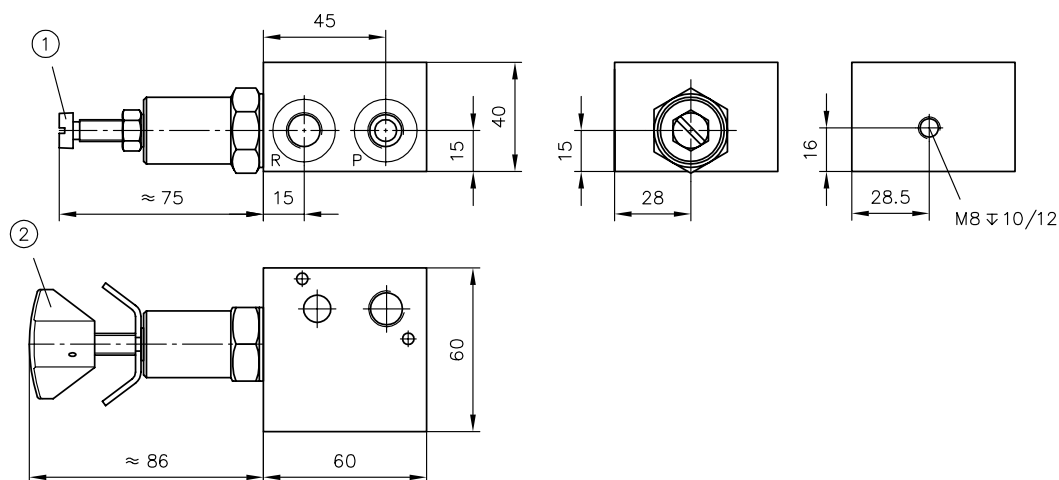

- 1 Fixed
- 2 Adjustable

Type	A, R (BSPP)	
BVH 11 A5	G 1/4	DIN EN ISO 228-1
BVH 12 A5	G 3/8	DIN EN ISO 228-1
BVH 11 A5 JIS	G 1/4 JIS	JIS B 2351-1
BVH 12 A5 JIS	G 3/8 JIS	JIS B 2351-1
BVH 11 A1 JIS	G 1/4 JIS	JIS B 2351-1

4.2 Valve sections

Side hole pattern

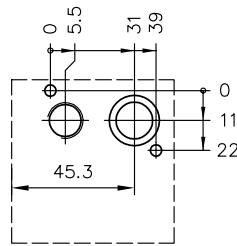

Actuation

Circuit symbol H, M, V, R, S, D, J

X.. (G.., L.., WG..)

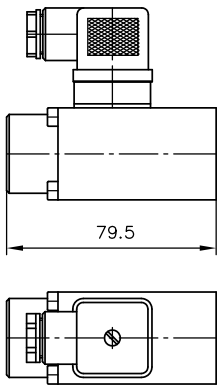

XM.. (GM.., LM.., WGM..)

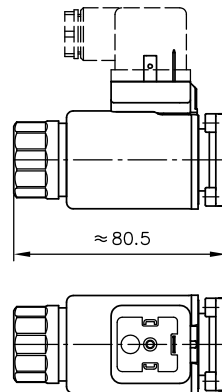

M24/8W

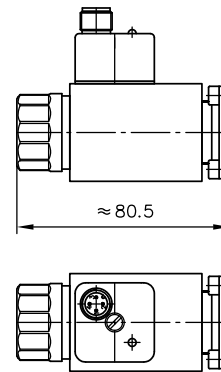

Circuit symbol G, W

X.. (G.., L.., WG..)

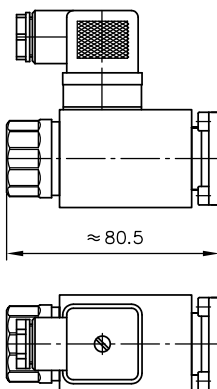

XM.. (GM.., LM.., WGM..)

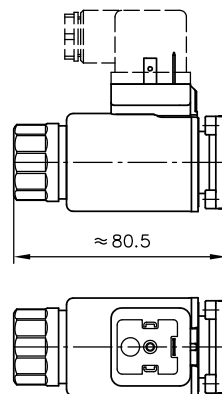

M24/8W

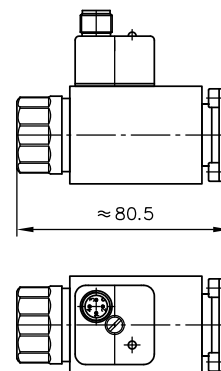

BVH 11 M..
 BVH 11 JIS M..
 BVH 11 H..
 BVH 11 JIS H..

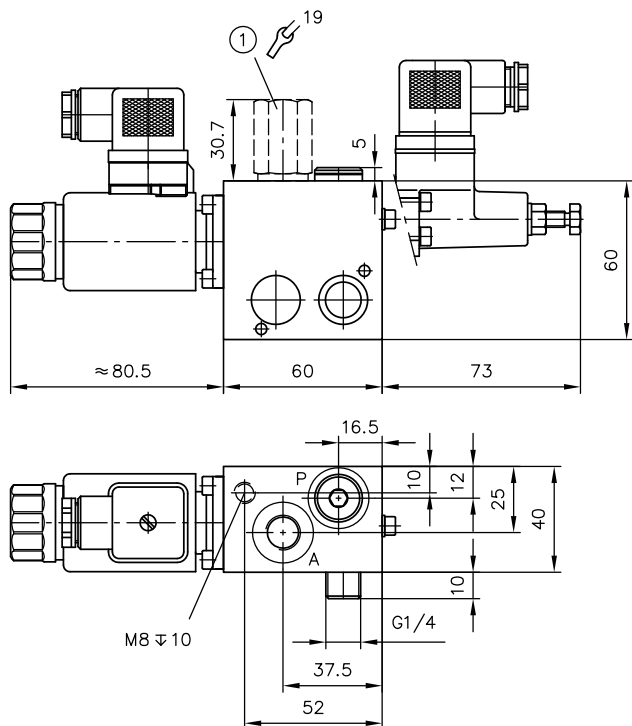

1 Additional element ABR..E(F)

Type	A (BSPP)		P (BSPP)	
BVH 11	G 1/4	DIN EN ISO 228-1	G 1/4	DIN EN ISO 228-1
BVH 11 JIS	G 1/4 JIS	JIS B 2351-1	G 1/4	DIN EN ISO 228-1

BVH 11 V..

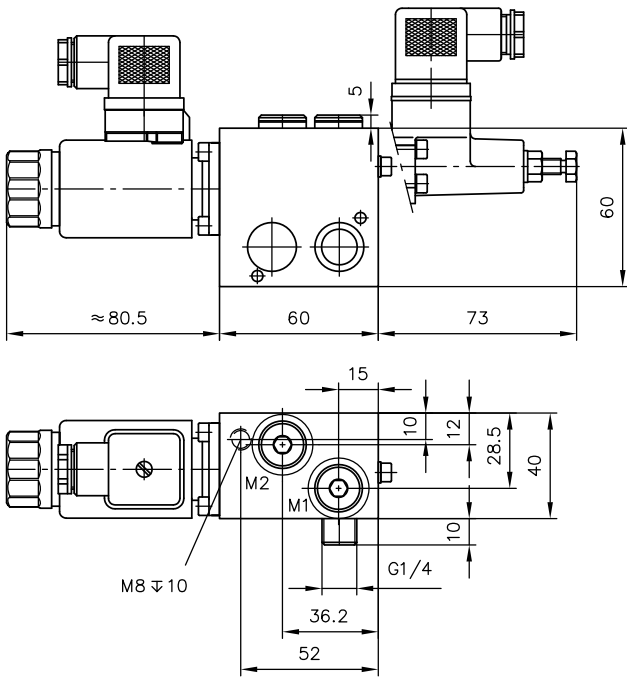

BVH 11 R..

BVH 11 S..

BVH 11 JIS R..

BVH 11 JIS S..

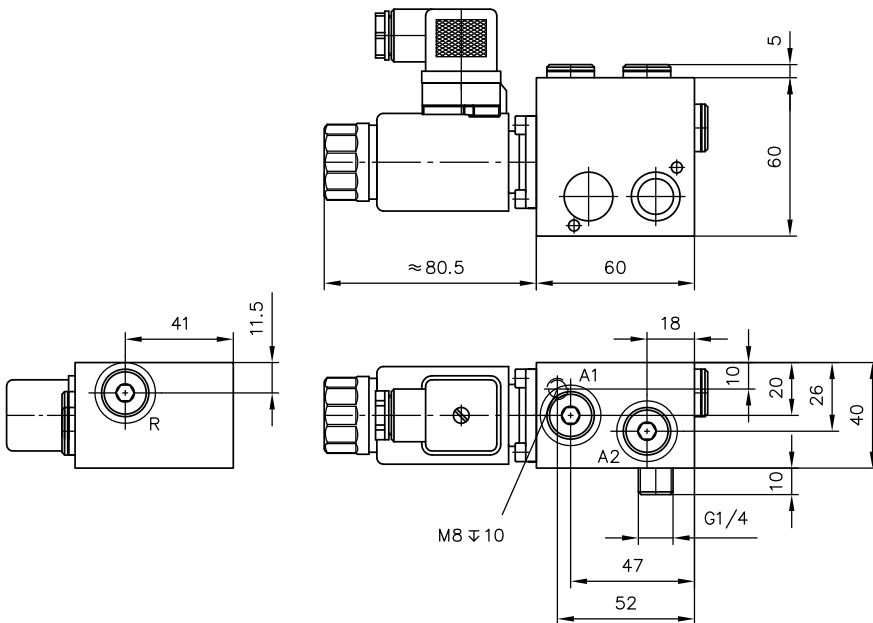

Type

A1, A2, M1, M2, R (BSPP)

BVH 11	G 1/4	DIN EN ISO 228-1
BVH 11 JIS	G 1/4 JIS	JIS B 2351-1

BVH 11 H/CZ..
 BVH 11 JIS H/CZ..

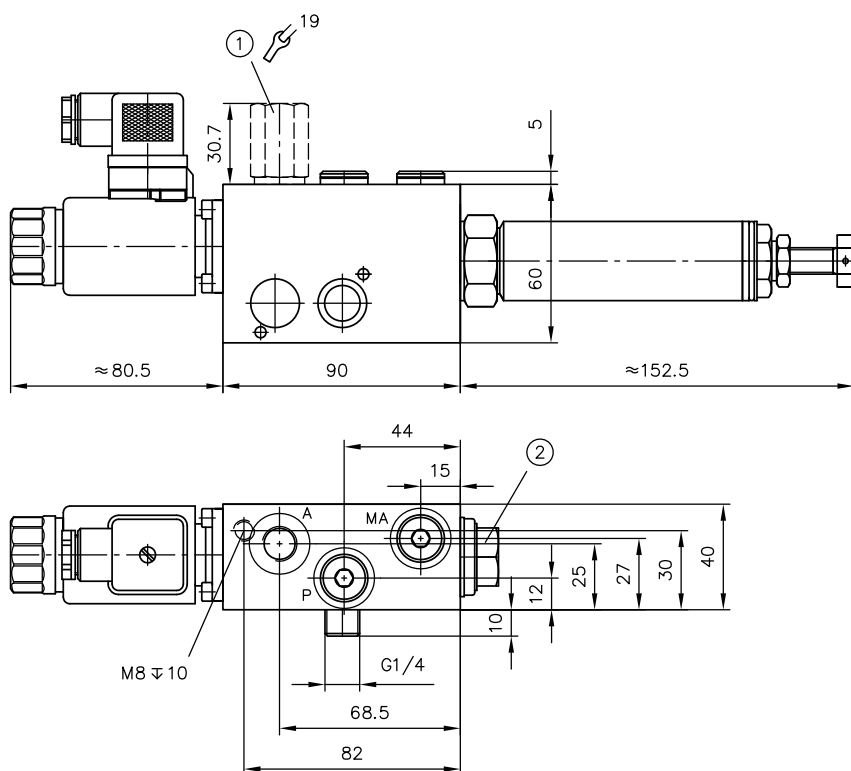

1 Additional element ABR..E(F)

2 For /CZX

Type	A (BSPP)		MA, P (BSPP)	
	Symbol	Standard	Symbol	Standard
BVH 11	G 1/4	DIN EN ISO 228-1	G 1/4	DIN EN ISO 228-1
BVH 11 JIS	G 1/4 JIS	JIS B 2351-1	G 1/4	DIN EN ISO 228-1

BVH 11 M/CZ..
BVH 11 JIS M/CZ..

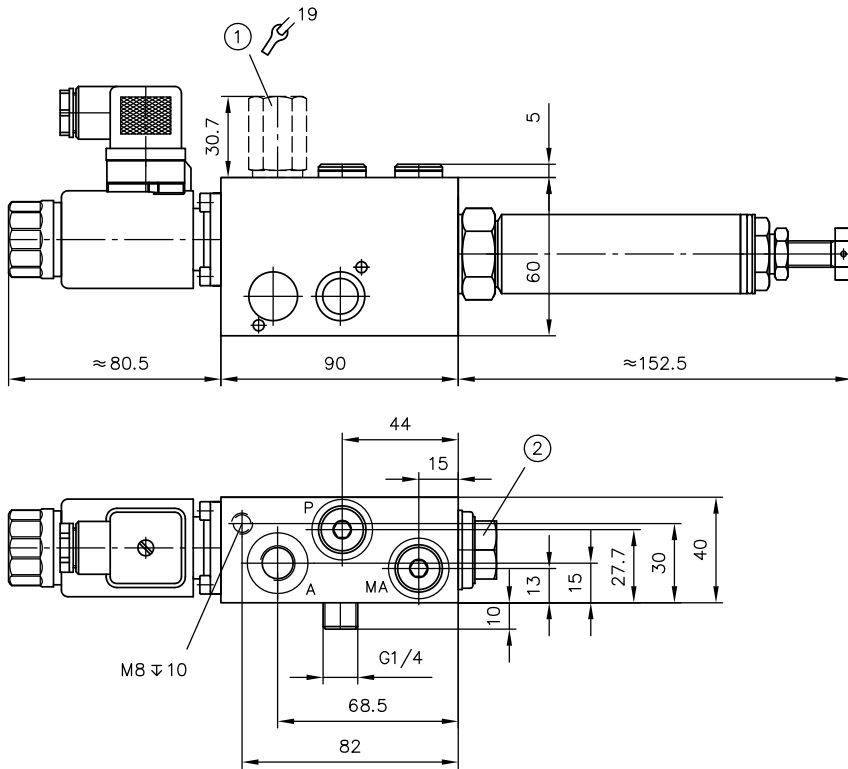

1 Additional element ABR..E(F)

2 For /CZX

Type	A (BSPP)		MA, P (BSPP)	
BVH 11	G 1/4	DIN EN ISO 228-1	G 1/4	DIN EN ISO 228-1
BVH 11 JIS	G 1/4 JIS	JIS B 2351-1	G 1/4	DIN EN ISO 228-1

BVH 11 G
BVH 11 JIS G

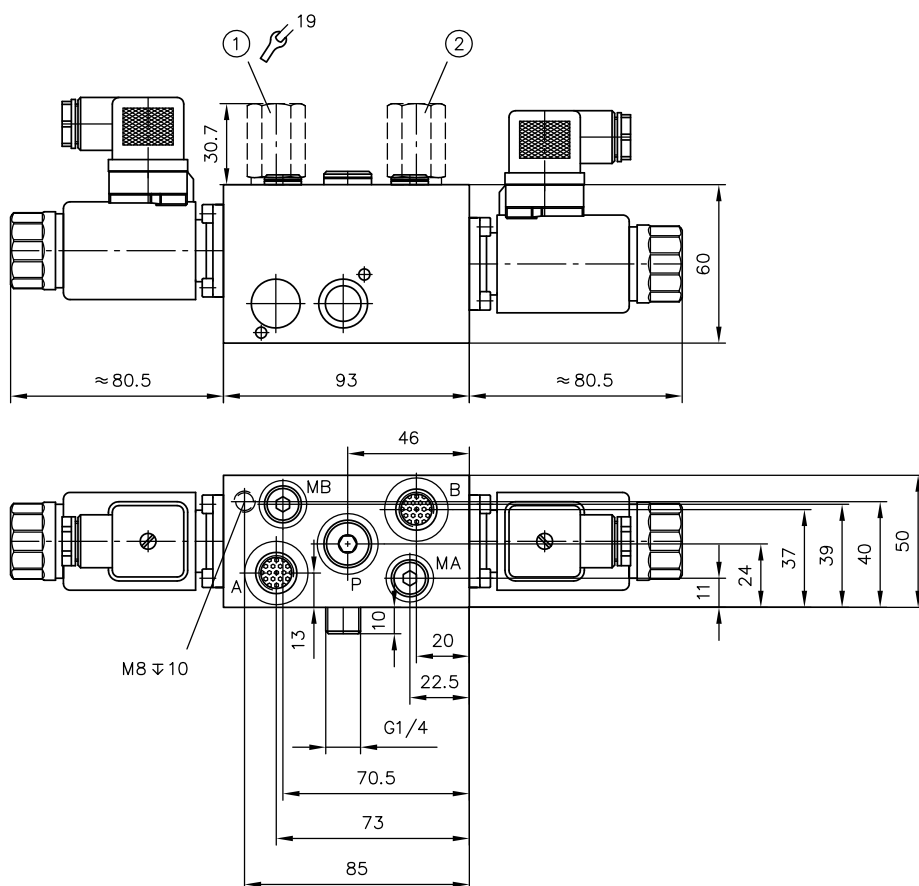

- 1 Additional element ABR..E(F)
- 2 Additional element BBR..E(F)

Type	A, B (BSPP)		P (BSPP)		MA, MB (BSPP)	
	Thread	Standard	Thread	Standard	Thread	Standard
BVH 11	G 1/4	DIN EN ISO 228-1	G 1/4	DIN EN ISO 228-1	G 1/8	DIN EN ISO 228-1
BVH 11 JIS	G 1/4 JIS	JIS B 2351-1	G 1/4	DIN EN ISO 228-1	G 1/8	DIN EN ISO 228-1

BVH 11 G/CZ..
BVH 11 JIS G/CZ..
BVH 11 G/LZ..

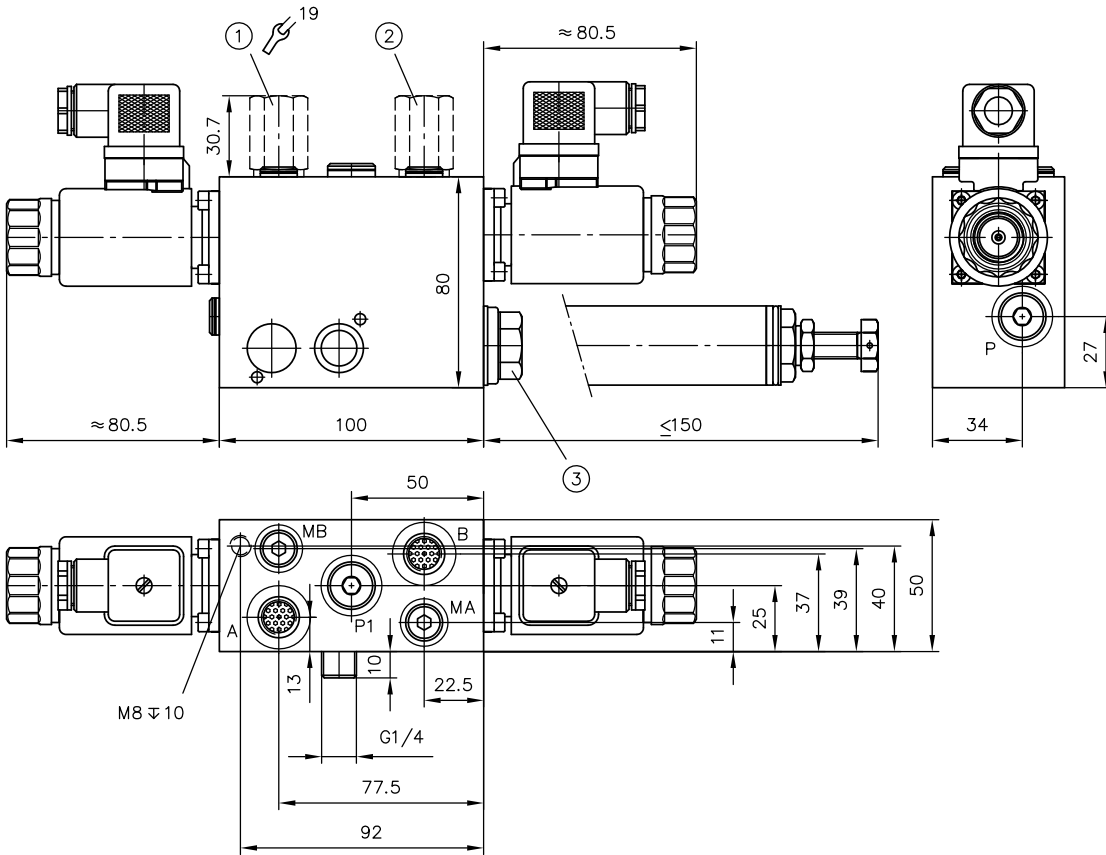

- 1 Additional element ABR..E(F)
2 Additional element BBR..E(F)
3 For /CZX

Type	A, B, P (BSPP)		P1 (BSPP)		MA, MB (BSPP)	
BVH 11	G 1/4	DIN EN ISO 228-1	G 1/4	DIN EN ISO 228-1	G 1/8	DIN EN ISO 228-1
BVH 11 JIS	G 1/4 JIS	JIS B 2351-1	G 1/4	DIN EN ISO 228-1	G 1/8	DIN EN ISO 228-1

BVH 11 D..
BVH 11 JIS D..

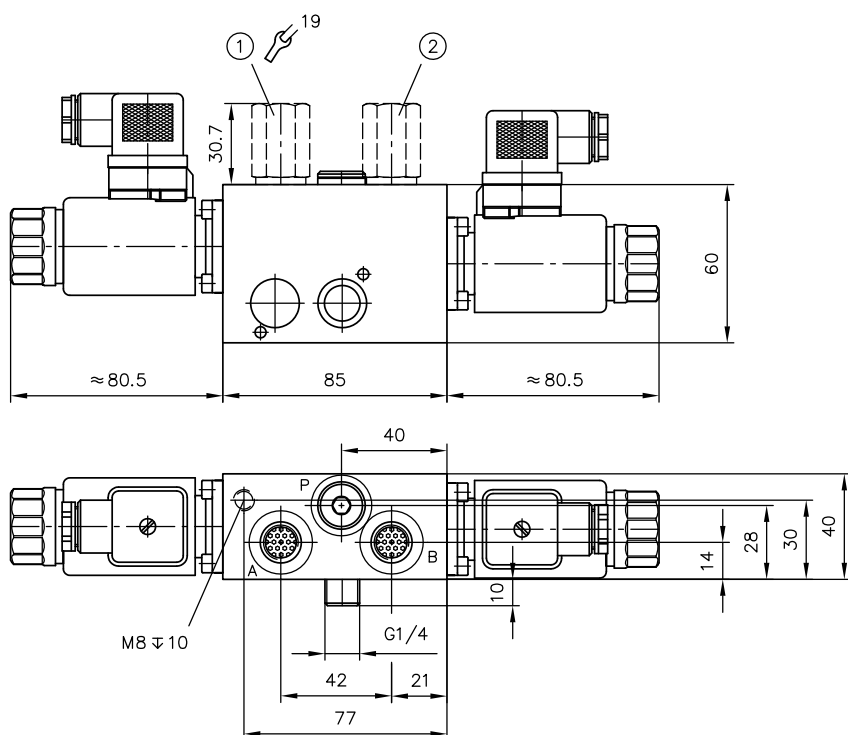

- 1 Additional element ABR..E(F)
- 2 Additional element BBR..E(F)

Type	A, B (BSPP)		P (BSPP)	
BVH 11	G 1/4	DIN EN ISO 228-1	G 1/4	DIN EN ISO 228-1
BVH 11 JIS	G 1/4 JIS	JIS B 2351-1	G 1/4	DIN EN ISO 228-1

BVH 11 J..

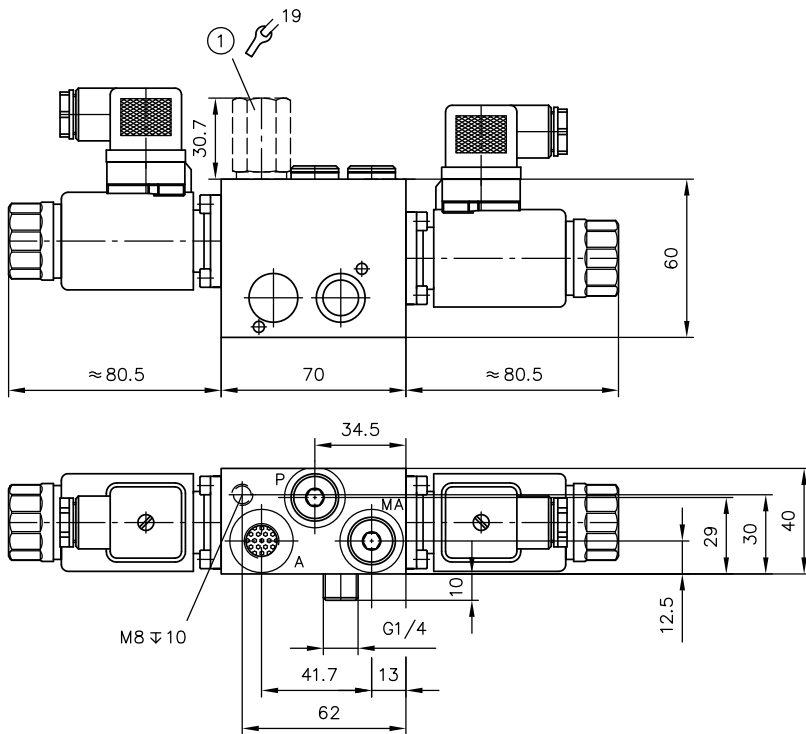

1 Additional element ABR..E(F)

Type	A, B (BSPP)		P, P1 (BSPP)	
BVH 11	G 1/4	DIN EN ISO 228-1	G 1/4	DIN EN ISO 228-1

BVH 11 JIS W..

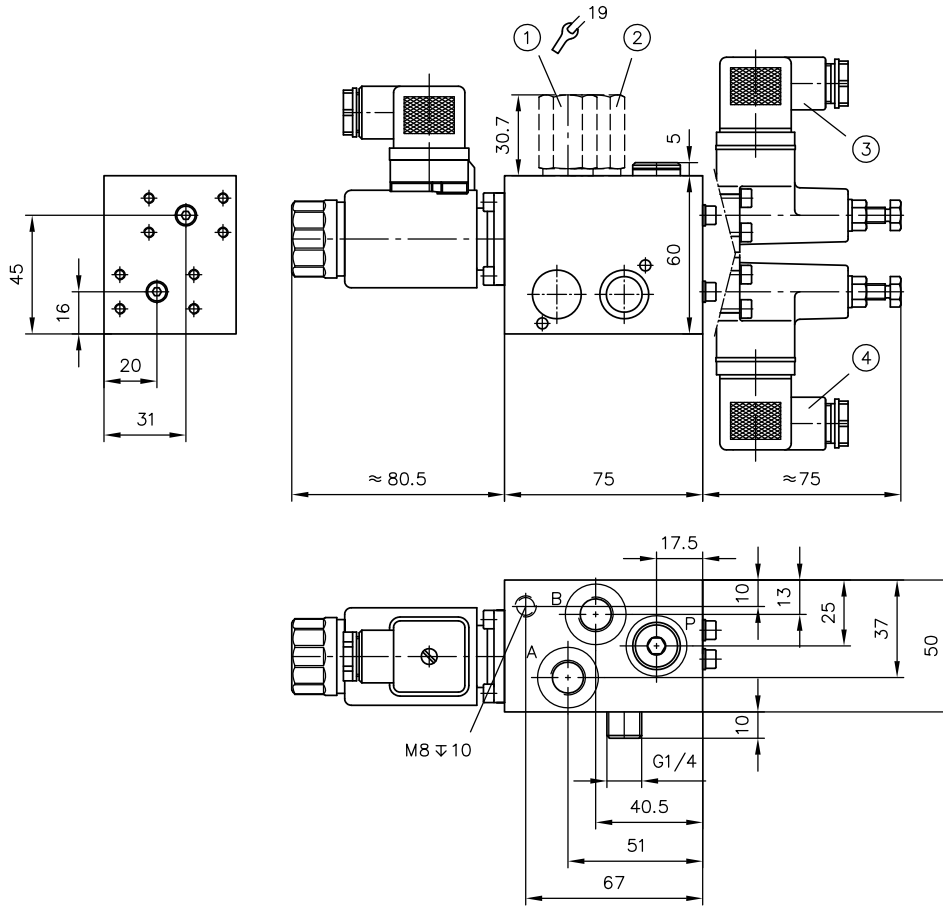

- 1 Additional element ABR..E(F)
- 2 Additional element BBR..E(F)
- 3 Pressure switches to B
- 4 Pressure switches from A

Type	A, B (BSPP)		P (BSPP)	
BVH 11	G 1/4	DIN EN ISO 228-1	G 1/4	DIN EN ISO 228-1
BVH 11 JIS	G 1/4 JIS	JIS B 2351-1	G 1/4	DIN EN ISO 228-1

BVH 11 W/CZ..
 BVH 11 JIS W/CZ..

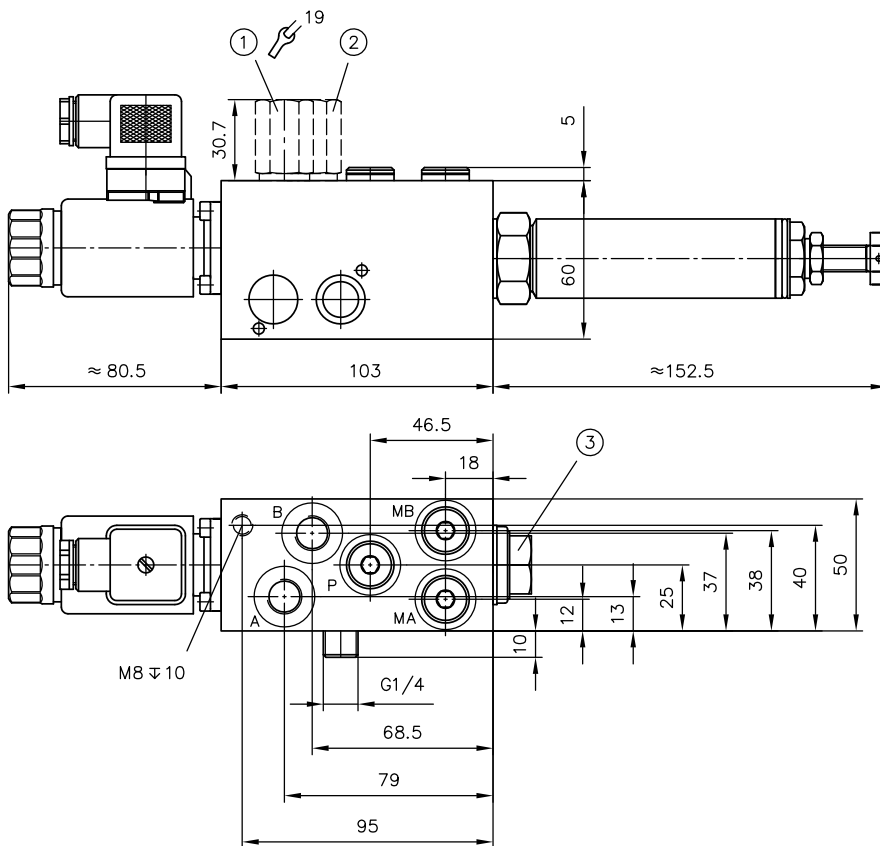

- 1 Additional element ABR..E(F)
- 2 Additional element BBR..E(F)
- 3 For /CZX

Type	A, B (BSPP)		MA, MB, P (BSPP)	
BVH 11	G 1/4	DIN EN ISO 228-1	G 1/4	DIN EN ISO 228-1
BVH 11 JIS	G 1/4 JIS	JIS B 2351-1	G 1/4	DIN EN ISO 228-1

BVH 11 CZD.../5...
BVH 11 LZD.../5...

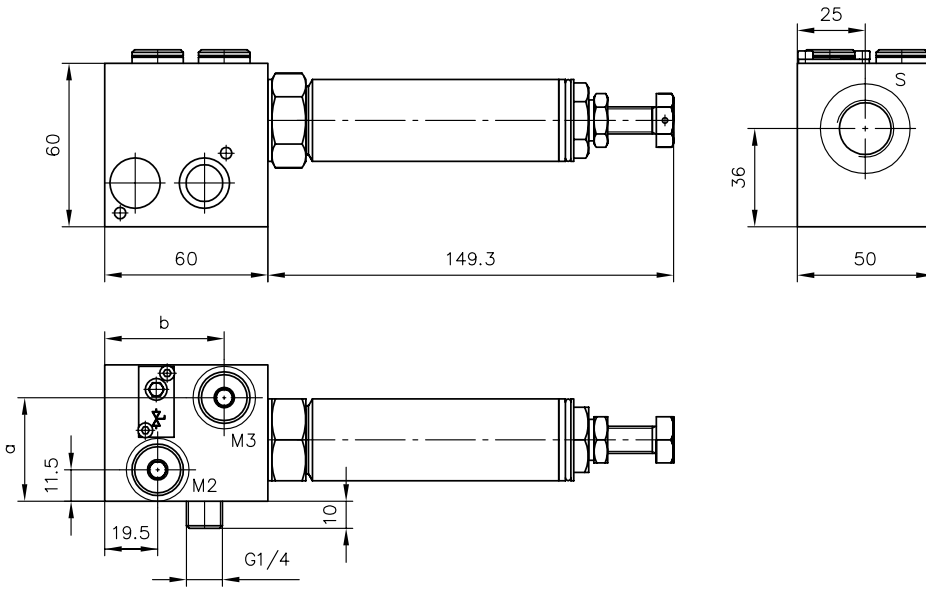

Type	a	b
BVH 11 CZD../5..	38	44
BVH 11 LZD../5..	38.5	38

BVH 11 Z1/...

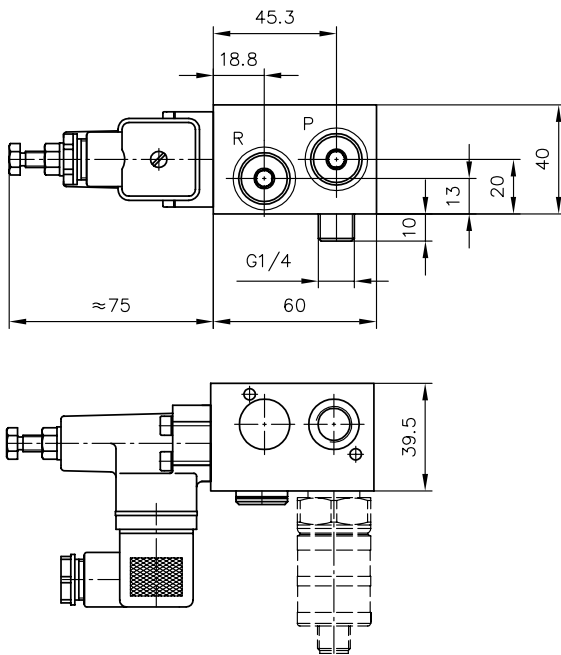

Type	M2, M3, R, P (BSPP)	S (BSPP)
BVH 11	G 1/4 DIN EN ISO 228-1	G 1/2 DIN EN ISO 228-1

BVH 11 ZD..

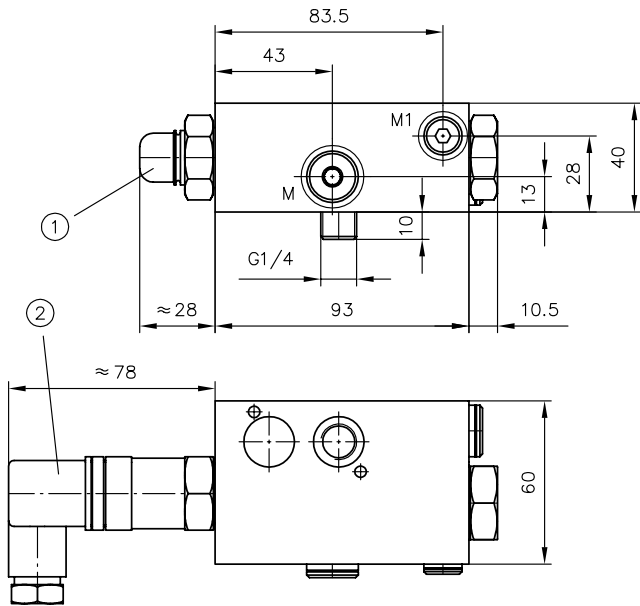

- 1 Coding VA, VV
- 2 Coding VE

BVH 11 ... /0

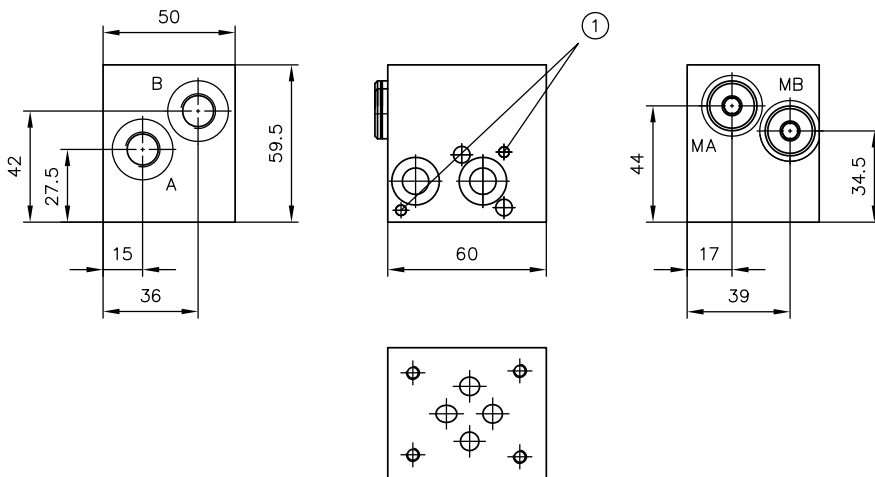

- 1 Centring pins ISO 8750-4x8-St

Type	A, B, M, MA, MB (BSPP)		M1 (BSPP)	
BVH 11	G 1/4	DIN EN ISO 228-1	G 1/8	DIN EN ISO 228-1

4.3 End plates

Finished with tapped plugs - 1

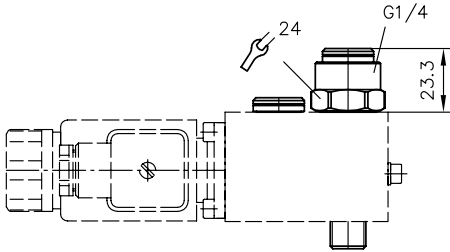

Finished with tapped plugs - 2

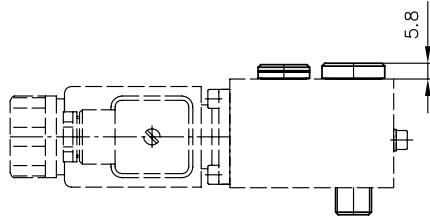

End plate - 81
- 81/B...

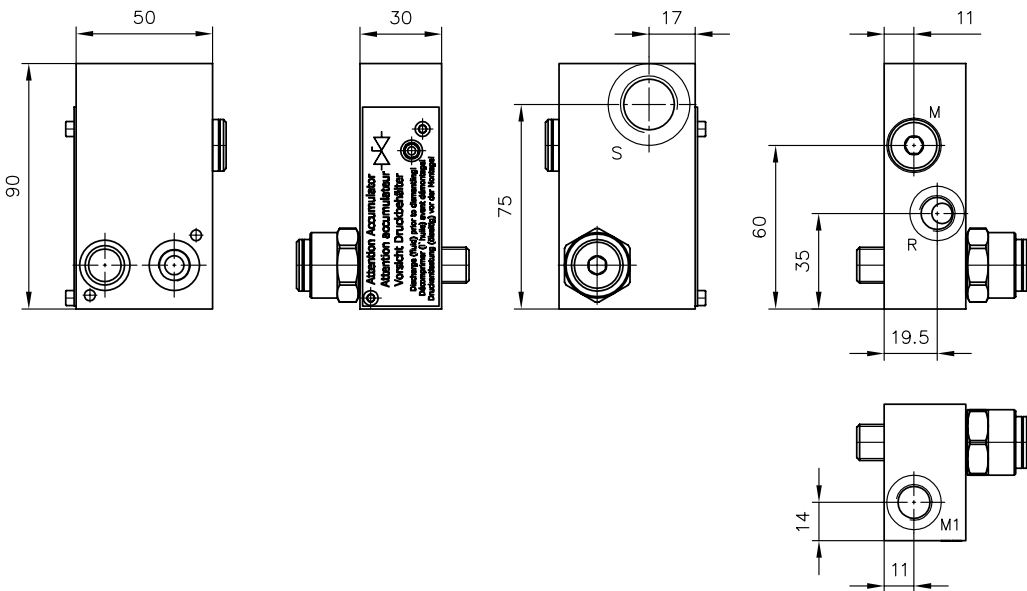

Type	S (BSPP)		M, M1, R (BSPP)	
- 81 - 81/B...	G 1/2	DIN EN ISO 228-1	G 1/4	DIN EN ISO 228-1

End plate - 82
- 82/B...

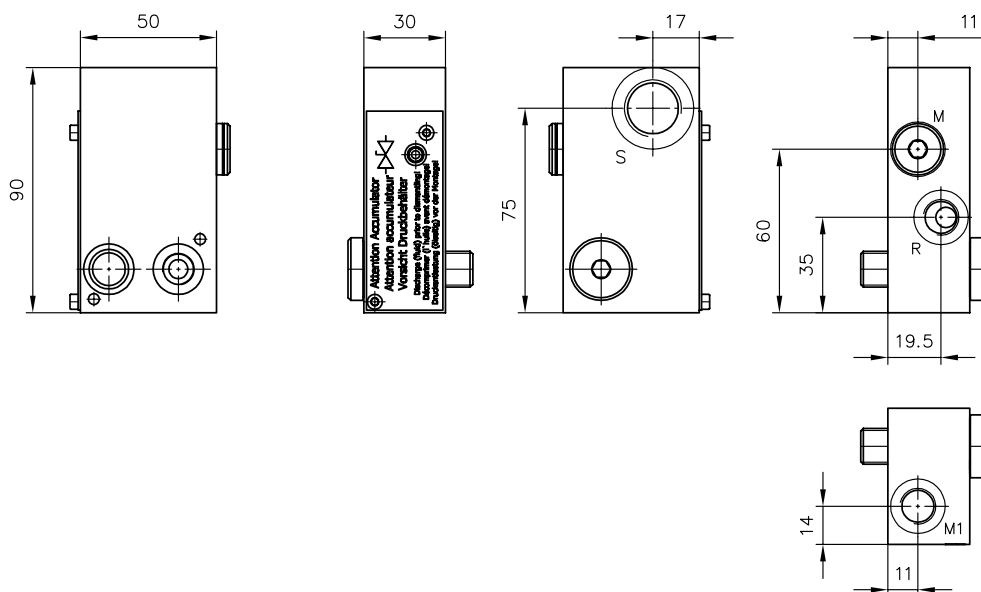

Type	S (BSPP)		M, M1, R (BSPP)	
- 82 - 82/B...	G 1/2	DIN EN ISO 228-1	G 1/4	DIN EN ISO 228-1

End plate - 82 JIS

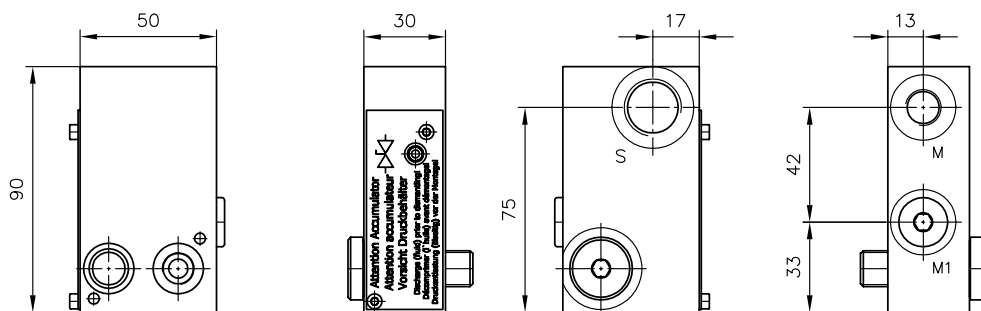

Type	S (BSPP)		M (BSPP)		M1 (BSPP)	
- 82 JIS	G 1/2	DIN EN ISO 228-1	G 1/4	DIN EN ISO 228-1	G 1/4 JIS	JIS B 2351-1

5.1 Intended application

This valve is intended exclusively for hydraulic applications (fluid engineering). The valve meets high technical safety standards and regulations for fluid and electrical engineering.

The user must observe the safety measures and warnings in this documentation.

Essential requirements for the product to function correctly and safely:

- All information in this documentation must be observed. This applies in particular to all safety measures and warnings.
- The product must only be assembled and put into operation by qualified personnel.
- The product must only be operated within the specified technical parameters. The technical parameters are described in detail in this documentation.
- The operating and maintenance manual of the specific complete system must also always be observed.

If the product can no longer be operated safely:

Remove the product from operation and mark it accordingly. It is then not permitted to continue using or operating the product.

5.2 Assembly information

The hydraulic system must only be installed in the complete system with standard connection components that comply with market requirements (screw fittings, hoses, pipes, etc.).

The hydraulic system must be shut down correctly prior to dismantling; this applies in particular to hydraulic systems with hydraulic accumulators.



Danger

Risk to life caused by sudden movement of the hydraulic drives when dismantled incorrectly!

Risk of serious injury or death.

- Depressurise the hydraulic system.
- Perform safety measures in preparation for maintenance.

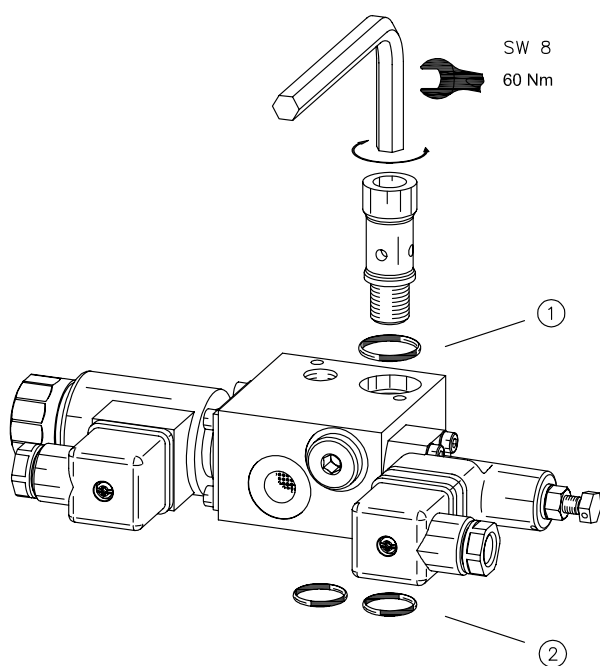

1 O-ring 18.77x1.78 P 5001

2 O-ring 15.00x2.00 P 5001

5.3 Operating instructions

Product configuration and setting the pressure and flow rate

The statements and technical parameters in this documentation must be strictly observed.
The instructions for the complete technical system must also always be followed.

Note

- Read the documentation carefully before usage.
- The documentation must be accessible to the operating and maintenance staff at all times.
- Keep documentation up to date after every addition or update.

Purity and filtering of the hydraulic fluid

Fine contamination can significantly impair the function of a hydraulic power pack. Contamination can cause irreparable damage.

Examples of fine contamination include:

- Metal chips
- Rubber particles from hoses and seals
- Dirt due to assembly and maintenance
- Mechanical debris
- Chemical ageing of the hydraulic fluid

Note

Fresh hydraulic fluid from the drum does not always have the highest degree of purity. Under some circumstances the fresh hydraulic fluid must be filtered before use.

Pay attention to the cleanliness level of the hydraulic fluid in order to maintain faultless operation.
(Also see cleanliness level in [Chapter 3, "Parameters"](#).)

5.4 Maintenance information

This product is largely maintenance-free.

Conduct a visual inspection at regular intervals, but at least once per year, to check if the hydraulic connections are damaged. If external leakages are found, shut down and repair the system.

Clean the device surface of dust deposits and dirt at regular intervals, but at least once per year.

Control of the visual clogging indicator for pressure filter

A red piston becomes visible once the response pressure is reached. In this case, replace the pressure filter cartridge.

6 Other information

6.1 Implementation examples

Circuit example:

KA 281 SKT/Z 5,2

- AX 14E/120
- BVH 11 ZD 10/SX/VV
- BVH 11 W/GM/0/52
- BVH 11 G/CZ 5/50/GM/0/BBR 1,0 E
- BVH 11 H/GM/0/5
- 81 - GM 24
- X 84 W-DG 62 R-9/160
- AC 1002/80/3 A3 x 400 V 50 Hz

Type KA compact hydraulic power pack 1 kW motor power; connection block with return line filter and TÜV-approved safety valve set to 120 bar.

Type BVH valve bank with three valve sections, two clamping functions with individually adjustable clamping pressure.

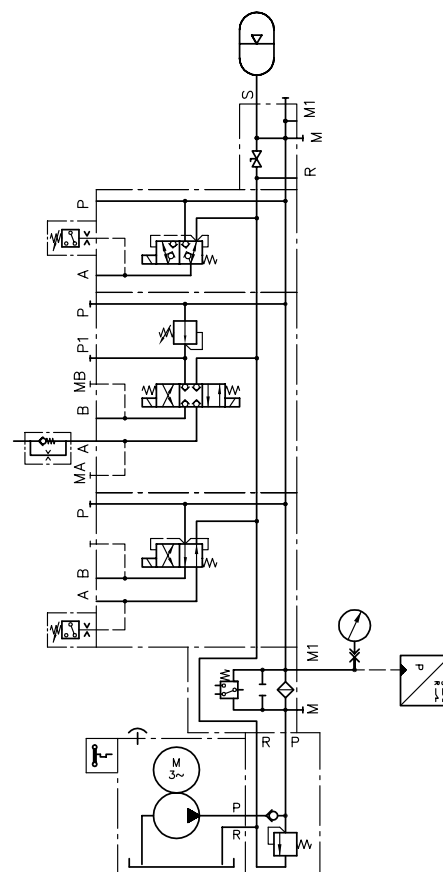
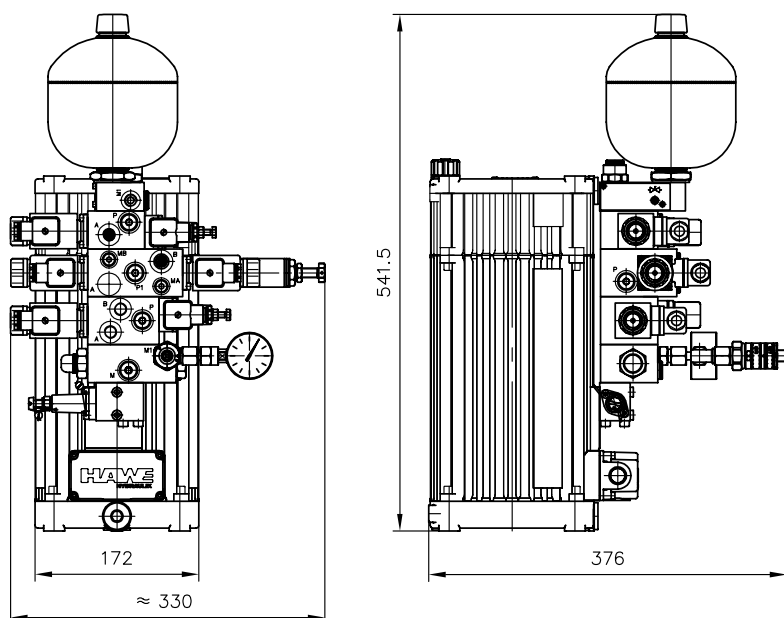

6.2 Planning information

When combining with hydraulic accumulators, the permissible flow rate must be respected. An orifice may need to be incorporated between the accumulator and directional valves.

6.3 Individual components

Coding	Description	Designation of individual components
R	Check valve at P	RK 1 according to D 7445
B..	Orifice at P	Orifice G-M8x-...-ST according to SK orifice Orifice diameter in mm
H	Filter element at A, B	HFC 1/4 according to D 7235
S	Return pressure stop at T	RK 1 according to D 7445
TB..	Orifice at T	Orifice according to SK 7445 400
ABR..E(F) BBR..E(F)	Restrictor check valve at A, B	BC 1-..E, BC 1-..F according to D 6969 B
ABRX 1,5 E(F) BBRX 1,5 E(F)		BC 1X-1.5 E, BC 1X-1.5 F according to D 6969 B
- 8. /B..	Orifice in the end plate	Orifice G-M8x-...-ST according to SK orifice Orifice diameter in mm
	Filter element	10 µm - 7953 834-F10 25 µm - 7953 834-F25 40 µm - 7953 834-F40
	Banjo bolt	8050 002
	O-ring 18.77x1.78 P5001 O-ring 15.00x2.0 P5001	

Further information

Additional versions

- Connection blocks type A for hydraulic power packs: D 6905 A/1
- Connection block type AX, with unit approval: D 6905 TUV
- Compact pump type MP: D 7200
- Compact hydraulic power pack type MP: D 7200 H
- Compact hydraulic power pack type MPN and MPNW: D 7207
- Compact hydraulic power pack type HK 2: D 7600-2
- Compact hydraulic power pack type HK 3: D 7600-3
- Compact hydraulic power pack type HKL and HKLW: D 7600-3L
- Compact hydraulic power pack type HK 4: D 7600-4
- Compact hydraulic power pack type HC and HCW: D 7900
- Compact hydraulic power pack type KA and KAW size 2: D 8010
- Compact hydraulic power packs type KA and KAW size 4: D 8010-4
- Pressure switch type DG: D 5440
- Electronic pressure switch type DG 5: D 5440 E/1
- Electronic pressure switch type DG 6: D 5440 F
- Restrictor check valve type BC: D 6969 B
- High-pressure screen filter type HF: D 7235
- Check valve type RK and RB: D 7445
- Pressure-reducing valve type CDK: D 7745
- Pressure-reducing valve type CLK: D 7745 L